



# GUIDELINES FOR ROAD DRAINAGE SYSTEM



Department of Roads

Design Division  
Department of Roads  
Ministry of Works and Human Settlement

November, 2021

## FOREWORD

The Department of Roads is pleased to bring out the *Guidelines for Road Drainage System* which is the first of its kind to provide information and guidance on considering a proper drainage system when constructing or rehabilitating a road structure.

Adequate drainage is a primary requirement for maintaining the structural soundness and functional efficiency of a road. Pavement structure including subgrade must be protected from any ingress of water; otherwise over a period of time it may weaken the subgrade by saturating it and cause distress in the pavement structure. That is why rapid dispersal of water from pavement and subgrade is a basic consideration in road design. This guideline will cover on the types of road drainage systems, design methodologies for constructing various types of drains and the standard recommended drainage sizes for various roads.

The department hopes that this guideline will benefit in constructing cost effective and longer lasting drainage system constructed by all the sectors involved in road constructions.



**(Tenzin)**

Director General  
Department of Roads

## Contents

|   |    |
|---|----|
| 1. Introduction .....   | 3  |
| 2. Road Drainage System.....  | 3  |
| 2.1 Surface Drainage .....  | 3  |
| 2.1.1 Road Geometric Design Consideration for Drainage.....               | 3  |
| 2.1.1.1 Longitudinal gradient of pavement.....                            | 3  |
| 2.1.1.2 Pavement cross-fall or camber .....                               | 3  |
| 3. Hydrological Design of Roadside Drains: .....                          | 5  |
| 3.1 Rainfall Data:.....   | 5  |
| 3.2 Discharge Design Methodologies.....                                   | 5  |
| 3.2.1 Empirical Formula: .....  | 5  |
| 3.2.2 Rational method: .....  | 6  |
| 4. Hydraulic Design of Road Drainage .....                                | 7  |
| 4.1 Open Channel Design.....  | 8  |
| 4.2 Triangular channel section .....                                      | 9  |
| 4.3 V-Shaped Channel Section .....  | 10 |
| 5. Drains in hilly terrain.....   | 13 |
| 5.1 Typical roadside drain .....  | 14 |
| 6. Drainage Construction:.....  | 15 |
| 7. Cross-Drainage Works .....   | 16 |
| 8. Subsurface Drainage.....   | 18 |
| 8.1 Granular Sub-Base as a Subsurface drainage:.....                      | 19 |
| 8.2 Aggregate Drains/ French Drains .....                                 | 20 |
| 9. Recommended Drainage size for Highways, Dzongkhag and Farm Roads ..... | 24 |

## List of Tables

|  |    |
|--|----|
| Table 1: Recommended Cross Slope for surface water disposal .....                | 4  |
| Table 2: Coefficient of Runoff ‘P’ .....   | 7  |
| Table 3: Manning’s coefficient and maximum permissible velocities for drain..... | 9  |
| Table 4: Grading for Granular Subbase Materials .....                            | 19 |
| Table 5: Grading Requirements for Aggregate Drains .....                         | 20 |

## List of Figures

|   |           |
|---|-----------|
| Figure 1: Typical Two-way Camber Cross Slope for Double Lane.....   | 4         |
| Figure 2: Typical One-way Camber Cross Slope in Super Elevated Sections for Double Lane4                    |           |
| Figure 3: Typical One-way Camber Cross Slope for Single Lane.....   | 4         |
| Figure 4: ‘f’ curve (IRC: SP: 13) .....   | 7         |
| Figure 5: Flow in Triangular Gutter Section (IRC: SP: 42-2014) .....  | 12        |
| Figure 6: Ratio of Frontal Flow of Total Gutter Flow (IRC: SP: 42-2014).....                                | 13        |
| Figure 7: Concrete Dykes or Benches on steep slope provided to reduce velocity .....                        | 14        |
| Figure 8: Typical U – Shaped Drain .....  | 14        |
| Figure 9: Typical Trapezoidal Drain .....   | 14        |
| Figure 10: Typical V-Shaped Drain .....   | 15        |
| Figure 11: Typical Composite Drain.....   | 15        |
| Figure 12: Typical Parabolic Drain.....   | 15        |
| Figure 13: Providing haunch by plastering the joints .....  | 16        |
| <i>Figure 14: Typical Hume Pipe culvert (extracted from RAP Project).....</i>                               | <i>17</i> |
| <i>Figure 15: : Typical Slab culvert (extracted from RAP Project) .....</i>                                 | <i>18</i> |
| Figure 16: Sources from which water/moisture reaches lower layers of pavement .....                         | 19        |
| Figure 17: Typical Subsurface drain below V-shaped drain .....  | 20        |
| Figure 18: Typical Subsurface drain below U-shaped drain .....  | 21        |
| Figure 19: Typical Subsurface drain below the pavement.....   | 21        |
| Figure 20: Typical Aggregate Drain on Slope (extracted from RAP Project) .....                              | 21        |
| Figure 21: Perforated HDPE/PVC pipe provided with the Aggregate drain (extracted from IRC: SP:42-2014)..... | 23        |
| Figure 22: Recommended V-Shaped Drain for Highways and Dzongkhag Road.....                                  | 24        |
| Figure 23: Recommended V-Shaped Drain for Farm Roads .....  | 24        |
| Figure 24: Recommended U-Shaped Drain for Highways and Dzongkhag Roads.....                                 | 25        |
| Figure 25: Recommended U-Shaped Drain for Farm Roads.....   | 25        |

## 1. Introduction

A good road drainage system forms an integral part of the road design and, with proper planning, enhances the longevity of the road structure. It is imperative to consider the rapid dispersal of water from the surface and subsurface of the pavement as prolonged interaction leads to the weakening of the pavement structure. This weakening in the pavement structure is often manifested in the form of potholes, rutting, swelling of the subgrade, stripping of aggregates, washed-out shoulder, etc. These problems, however, can be eliminated by channeling water through a designated path and dispersing it into the natural gully. Therefore, this guideline is aimed at providing a comprehensive guide in considering a proper drainage system when constructing or rehabilitating a road structure.

## 2. Road Drainage System

Drainage systems on roads consist of two types, and they are surface and subsurface drainage. The surface drainage consists of providing longitudinal drainage whereby the precipitated water is channelized through a designated path along the road and is disposed of through a transverse or cross drainage structure like culverts and bridges. The subsurface drainage is provided to channel underground water through an uninterrupted path which otherwise would have been disturbed by the road formation cutting, especially on hilly roads. Moreover, subsurface drainage functions to lower the water table and help channel any ingress of water from the top of pavement through cracks and leaked joints to a proper outfall. In order to have an appropriate drainage system, a proper survey and investigation must be carried out by incorporating but not limited to the following activities:

1. Topographical study of the road alignment
2. Hydrological studies such as rainfall analysis and runoff estimation
3. Hydraulic design
4. Geotechnical investigation

### 2.1 Surface Drainage

#### 2.1.1 Road Geometric Design Consideration for Drainage

For any new road construction, the selection of road alignment can have a vital bearing on the drainage system. It is important that drainage is considered as one of the criteria when choosing a new road alignment. In general, road alignment passing through a marshy area and those running parallel in close proximity to rivers and streams should be avoided as they are likely to give rise to constant moisture-related problems and affect the serviceability period of the pavement structure. Following introduction to the road geometry are found to aid in the rapid dispersal of surface water from the pavement:

##### 2.1.1.1 The longitudinal gradient of pavement

Flat surfaces are prone to water stagnation and hence not desired in the longitudinal profile of the road. In order to avoid stagnation and facilitate quick removal of surface water from the pavement, it is required to provide a minimum longitudinal gradient of 0.3 to 0.5 percent depending on the suitability of the site.

##### 2.1.1.2 Pavement cross-fall or camber

Pavement cross-fall or camber are provided to rapidly drain surface water from pavement to

the adjacent drains or natural slope. The slope of the cross-fall, however, depends on the material of the pavement. Providing a steeper cross slope in the case of earthen/granular could result in erosion of the surface. The following table shows the recommended cross-slope for various pavement materials:

*Table 1: Recommended Cross Slope for surface water disposal*

| Surface Type                      | Cross-slope   |
|-----------------------------------|---|
| Earthen, Graveled, or GSB surface | 3 – 5 %   |
| Bituminous surfacing              | 2 – 3 %   |
| Cement concrete surface           | 2 – 2.5 % in case of transverse tine or brush texturing |
|                                   | 2.5 % in case of longitudinal tine texturing            |

Recommended ways to provide camber in different pavement configurations on hilly roads:

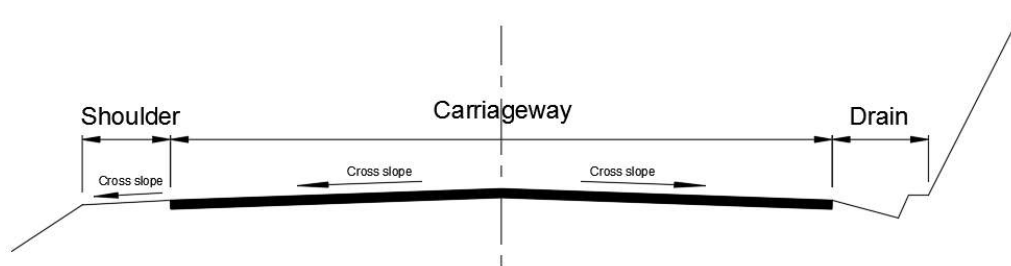

*Figure 1: Typical Two-way Camber Cross Slope for Double Lane*

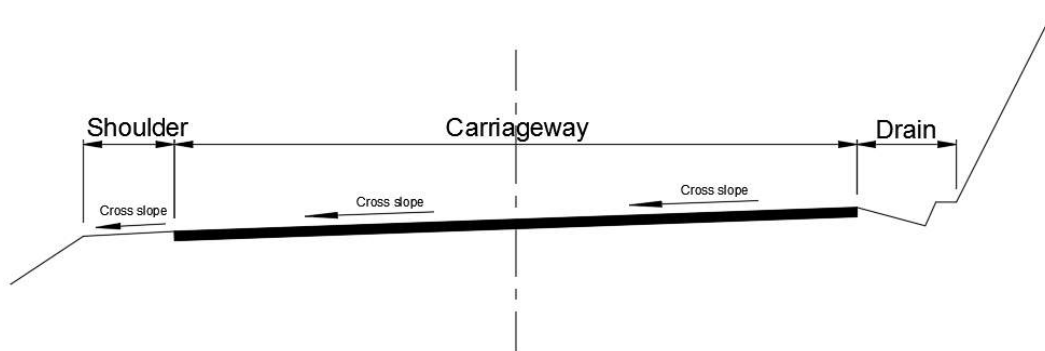

*Figure 2: Typical One-way Camber Cross Slope in Super Elevated Sections for Double Lane*

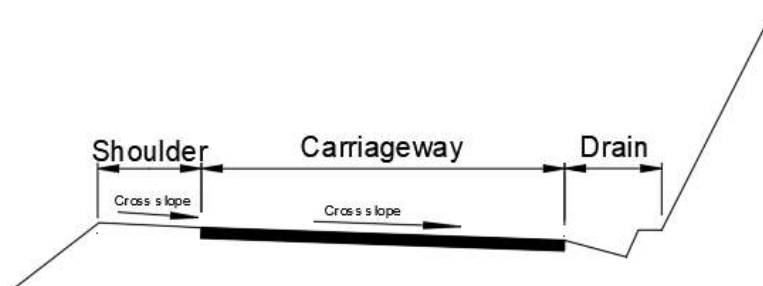

*Figure 3: Typical One-way Camber Cross Slope for Single Lane*

### 3. Hydrological Design of Roadside Drains:

Hydrological design of road drainage system is the study and analysis of the physical characteristics of catchment, intensity-duration characteristics of rainfall of different frequencies to arrive at a suitable method of predicting design (peak) flood and corresponding HFL. This study is an important step prior to the hydraulic design of road drainage system. It is required to analyze the size and shape of the catchment area, topography, land use characteristics, natural storage, soil type, soil cover, drainage pattern, rainfall intensity, time of concentration, and peak flood/discharge. Road drainage structure ranges from small roadside drains and culverts to large drain systems comprising minor and major bridges.

The roadside drainage originates at the highest point of the road alignment and runs along with the pavement until the identified lowest point or outfall. Since with the increase of drainage length, the corresponding design discharge and, consequently, the cross-section of drain goes on increasing; it is crucial to identify the highest and lowest points of the road alignment and propose a suitable location of outfall in order to come up with a drain that is economical and reasonable in shape and size. The discharge from the roadside drain is usually connected to a natural outfall or adequately designed cross-drainages like culverts.

#### 3.1 Rainfall Data:

The collection of rainfall data is an integral part of the hydrological study and, therefore, should be given due importance in maintaining rainfall records for all times. However, in the absence of a rain gauge in certain areas, the records available with the National Center for Hydrology and Meteorology for certain areas could be used in deriving rainfall intensity and coming to a reasonable design discharge. The rainfall data can be acquired by submitting the data requisition form available on the NCHM website to the Hydrology and Water Resources Services Division.

#### 3.2 Discharge Design Methodologies

The estimation of design discharge that is required to be disposed of at a given instant can be done either by using empirical or rational formulae for a catchment.

##### 3.2.1 Empirical Formula:

Dickens Formula

$$Q = CA^{\frac{3}{4}} \dots\dots\dots 3.2.1.1$$

Where,

- Q = the peak runoff in  $m^3/sec$
- A = the catchment area in  $km^2$
- C = Dickens constant
  - = 6 where annual rainfall in below 60 cm
  - = 11 – 14 where annual rainfall is 60 – 120 cm

=14 – 19 where annual rainfall is more than 120 cm

3.2.2 Rational method:

$$Q = 0.028 P f A I \quad \dots\dots\dots 3.2.2.1$$

Where,

- Q = Maximum runoff in cum/sec
- A = Catchment area in hectares
- P = Coefficient of runoff for the given catchment characteristics (Table)
- f = Spread factor for converting point rainfall into areal mean rainfall
- I = Design rainfall intensity in cm/hr.

$$I = \frac{F}{T} \left[ \frac{T+1}{t+1} \right] \quad \dots\dots\dots 3.2.2.2$$

Where,

- I = Intensity of rainfall within a shorter period of 't' hours within a storm
- F = Total rainfall in a storm in cm falling in the duration of the storm of 'T' hours
- t = Smaller time interval in hours within the storm duration of 'T' hours
- T = Duration of total rainfall (F) in hours

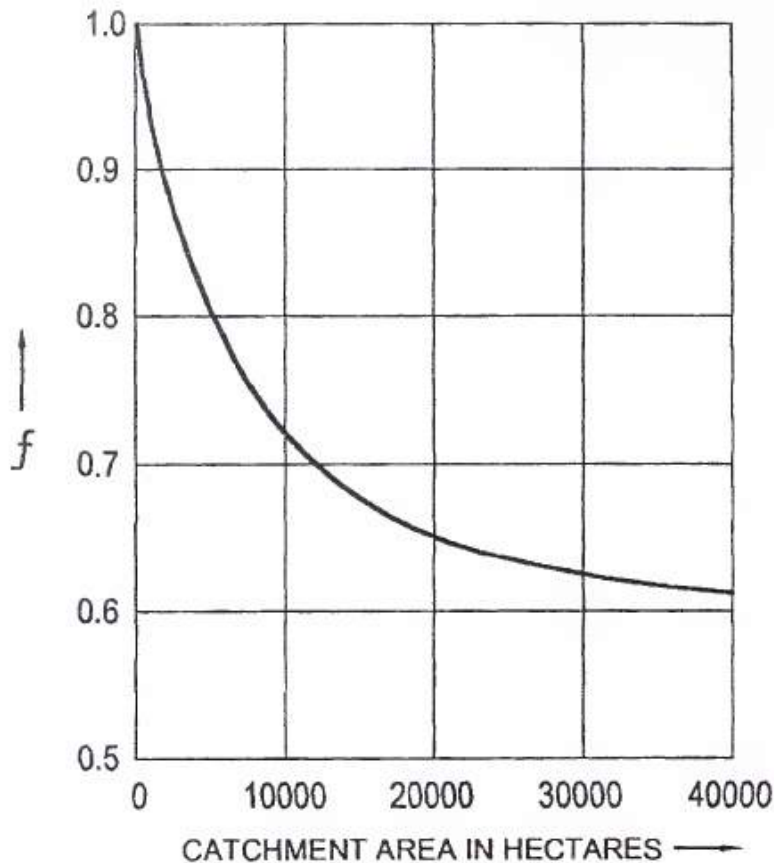

Figure 4: 'f' curve (IRC: SP: 13)

Table 2: Coefficient of Runoff 'P'

| Description of Surface  | Coefficient of Runoff (P) |
|---|---------------------------|
| Steep, bare rock, and watertight pavement surface (concrete or bitumen)                   | 0.9                       |
| Steep rock with some vegetative cover   | 0.8                       |
| Plateaus area with lightly vegetative cover   | 0.7                       |
| Bare stiff clayey soils (impervious soils)  | 0.6                       |
| Stiff clayey soils (impervious soils) with vegetative cover and uneven paved road surface | 0.5                       |
| Loam lightly cultivated or covered and macadam or gravel roads                            | 0.4                       |
| Loam largely cultivated or turfed   | 0.3                       |
| Sandy soil, light growth, parks, gardens, lawns, and meadows                              | 0.2                       |
| Sandy soil covered with heavy brush or wooded/forested areas                              | 0.1                       |

#### 4. Hydraulic Design of Road Drainage

Hydraulic design is carried out in order to provide an efficient drainage structure that will be able to withstand and cater to the design discharge. It ensures that the drainage structures are of sufficient size to accommodate and remain traversable. Following methodologies are adopted for the hydraulic design.

#### 4.1 Open Channel Design

In an open channel design considering steady uniform flow, the basic relationships are expressed by the use of Continuity and the Manning's equation:

Continuity Equation

$$Q = A_1V_1 = A_2V_2 \quad \dots\dots\dots 4.1.1$$

The subscripts 1 and 2 refer to the successive cross-section in the uniform flow path

Manning's Equation

$$Q = \frac{1}{n}AR^{\frac{2}{3}}S^{\frac{1}{2}} \quad \dots\dots\dots 4.1.2$$

$$V = \frac{1}{n}R^{\frac{2}{3}}S^{\frac{1}{2}} \quad \dots\dots\dots 4.1.3$$

Channel Conveyance

$$Q = KS^{\frac{1}{2}} \quad \dots\dots\dots 4.1.4$$

Where,

Q = Discharge in Cum/Sec.

V = Mean velocity of flow in m/sec

K = Channel conveyance

$$= \frac{1}{n} (AR^{\frac{2}{3}}) \quad \dots\dots\dots 4.1.5$$

n = Manning's roughness coefficient

R = hydraulic radius in m

$$= \frac{A}{P} \quad \dots\dots\dots 4.1.6$$

A = Area of the flow cross-section in  $m^2$

P = Wetted perimeter in m

S = Energy slope of the channel, which is roughly taken as the slope of the drain bed

The flow of water in the design of the roadside channel is assumed as sub-critical flow. The slope and velocity are kept below the critical level. Critical depth of flow 'd<sub>c</sub>' in an open channel is that depth at which specific energy is minimum. On mild slope, flow is sub-critical and normal depth of flow 'd<sub>n</sub>' is more than critical depth.

For rectangular channel  $d_c = \left(\frac{Q^2}{b^2 g}\right)^{\frac{1}{3}}$  where 'g' is the acceleration due to gravity and b is the width of the channel. If d<sub>n</sub><d<sub>c</sub>, the slope and channel section should be redesigned so that d<sub>n</sub>>d<sub>c</sub>. Stepped chutes should be provided where the ground slope is steep.

The values of "n" for various channel surfaces are given in the table below:

*Table 3: Manning's coefficient and maximum permissible velocities for drain*

| Sl. No.  | Ditch Lining   | Manning's 'n' | Allowable velocity to prevent erosion m/sec |
|----------|--|---------------|---|
| <b>1</b> | <b>Natural Earth</b>                                   |               |   |
| A        | Without vegetation                                     |               |   |
|          | i) Rock  |               |   |
|          | Smooth and Uniform                                     | 0.035 – 0.04  | 6   |
|          | Jagged and irregular                                   | 0.04 – 0.045  | 4.5 – 5.5                                   |
|          | ii) Soil   | 0.02 – 0.026  | 0.3 – 2.1                                   |
| B        | With Vegetation  |               |   |
|          | Dense turf   | 0.03 – 0.05   | 0.9 – 1.2                                   |
|          | Channel with tree stumps                               | 0.04 – 0.5    | 1.5 – 1.8                                   |
| <b>2</b> | <b>Paved</b>   |               |   |
| A        | Concrete with all surfaces, Good or Poor               |               |   |
|          | i) Trowel finished                                     | 0.012 – 0.014 | 6   |
|          | ii) Float finished                                     | 0.013 – 0.015 | 6   |
|          | iii) Formed, no finish                                 | 0.014 – 0.016 | 6   |
| B        | Concrete bottom, float finished with sides of;         |               |   |
|          | i) Dressed stone in mortar                             | 0.015 – 0.017 | 5.4 – 6                                     |
|          | ii) Random stone in mortar                             | 0.017 – 0.2   | 5.1 – 5.7                                   |
|          | iii) Dressed stone or smooth concrete rubble (Rip-rap) | 0.02 – 0.025  | 4.5   |
|          | iv) Rubble or random stone (Rip-rap)                   | 0.025 – 0.03  | 4.5   |
| C        | Bitumen (Asphalt)                                      | 0.013 – 0.016 | 5.4 - 6                                     |

#### 4.2 Triangular channel section

The Manning equation cannot be used without modification to compute flow in right triangular sections as used in urban or hilly areas because hydraulic radius does not adequately describe the drain section, particularly when the top width of the water surface may be more than 40 times the depth of curb. To compute drain flow, the Manning equation

for an increment of width is integrated across the width, and the resulting formula is:

$$Q = \frac{0.315}{n} F_1(Z) d^{\frac{8}{3}} S^{\frac{1}{2}} \dots\dots\dots 4.2.1$$

Where,

- Z = Reciprocal of cross slope
- d = Depth of channel in m
- T = Spread of water in m

$$F_1(Z) = \frac{Z^{\frac{5}{3}}}{(1+\sqrt{1+Z^2})^{\frac{2}{3}}} \dots\dots\dots 4.2.2$$

In terms of spread width T in figure 4.2.1, the equation becomes

$$Q = \left(\frac{0.317}{n}\right) (S_x^{\frac{5}{3}} S^{\frac{1}{2}} T^{\frac{8}{3}}) \dots\dots\dots 4.2.3$$

### 4.3 V-Shaped Channel Section

Manning’s formula is

$$Q = \frac{1}{n} F_2(Z) d^{\frac{8}{3}} S^{\frac{1}{2}} \dots\dots\dots 4.2.4$$

Where,

$$F_2(Z) = \frac{0.63 Z^{\frac{5}{3}}}{(Z^2+1)^{\frac{1}{3}}} \dots\dots\dots 4.2.5$$

This equation could be corrected to give depth of flow ‘d’ as

$$d = 1.1892 \left[ \frac{Q \cdot n}{\sqrt{5}} \right]^{\frac{3}{8}} \left[ \frac{Z^2 + 1}{Z^{\frac{5}{8}}} \right]^{\frac{3}{8}} \dots\dots\dots 4.2.6$$

In terms of spread width T in figure 4.2.1, the equation is the same as EQ 4.2.3 with  $S_x$  defined as

$$S_x = \frac{S_{x1} \cdot S_{x2}}{(S_{x1} + S_{x2})} \dots\dots\dots 4.2.7$$

The hydraulic analysis of the channel provides the depth and mean velocity of flow at which a given flow will pass through the channel of known geometry, roughness, and slope. Depth and velocity of flow are necessary for the design or analysis of channel linings and highway drainage structures.

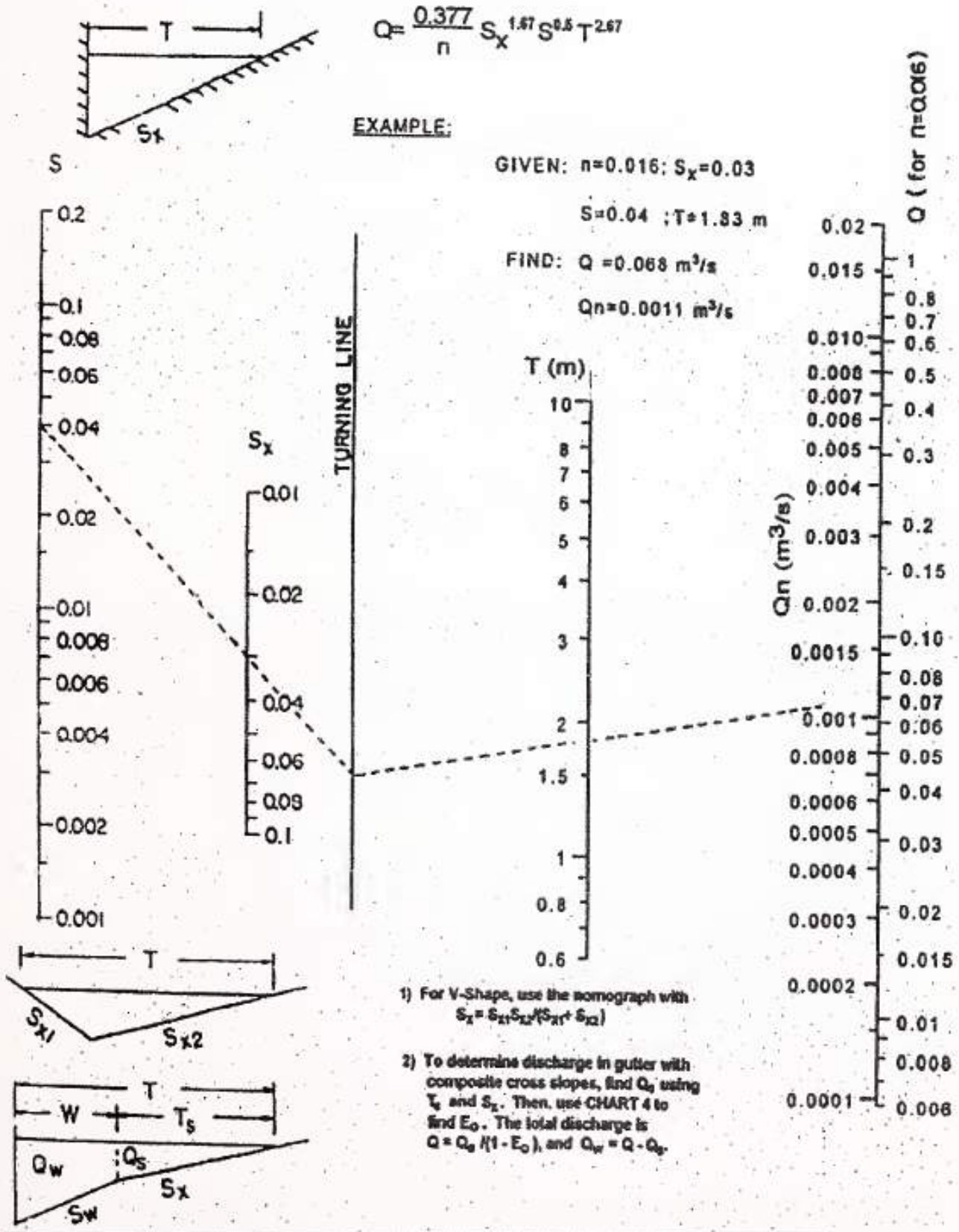

Figure 5: Flow in Triangular Gutter Section (IRC: SP: 42-2014)

To determine discharge in the gutter with composite cross-slope, find  $Q_s$  and  $T_s$  (for  $T$ ) and  $S_x$  in Equation – 5. Then using the figure below, find  $E_0$ . The total discharge is given by

$$Q = \frac{Q_s}{1-E_0} \quad \text{and} \quad Q_w = Q - Q_s \quad \dots\dots\dots 4.2.8$$

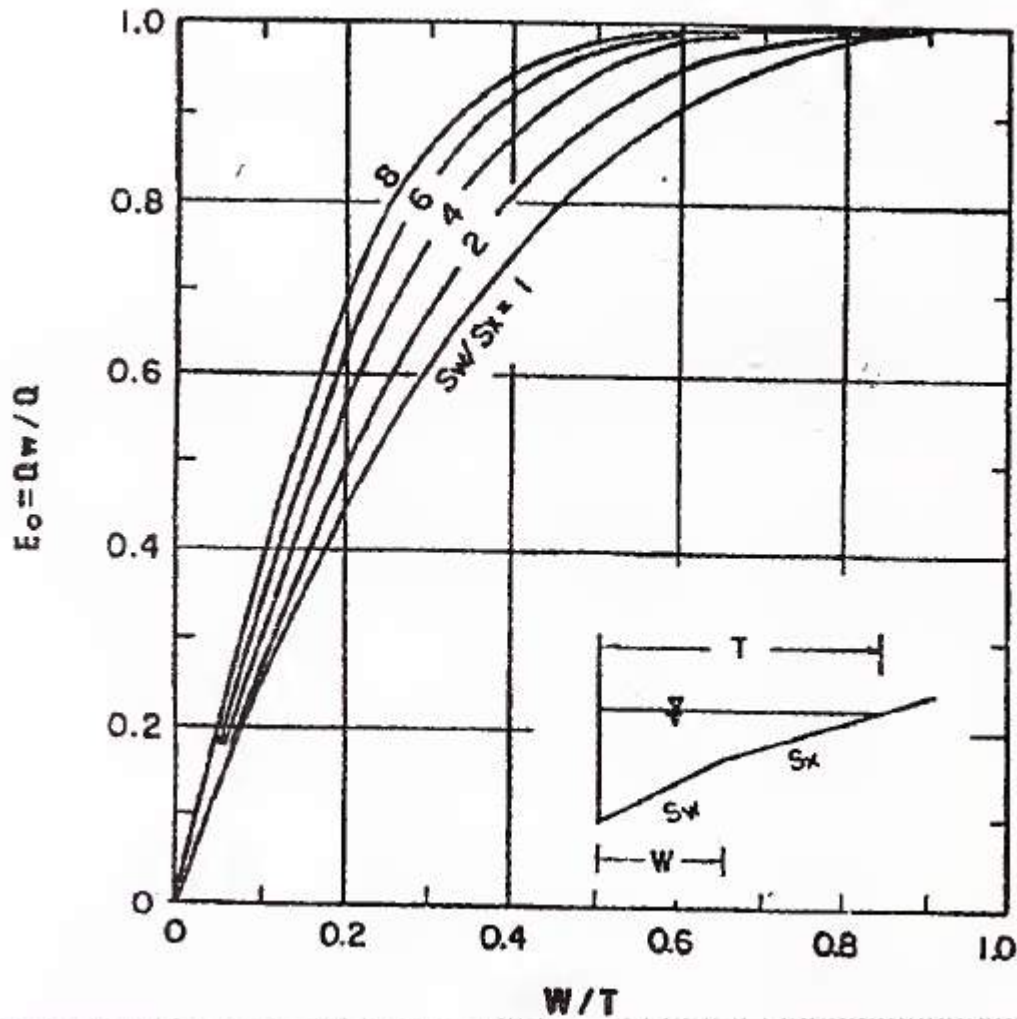

Figure 6: Ratio of Frontal Flow of Total Gutter Flow (IRC: SP: 42-2014)

## 5. Drains in hilly terrain

The flow of water in roadside drains in hilly terrain generally remains at a high velocity due to steep road gradients, which leads to erosion of drains. In order to break the flow velocity and minimize erosion of drains, it is recommended to provide no-fines concrete dykes or stone or concrete benches at the bottom of the lined drain.

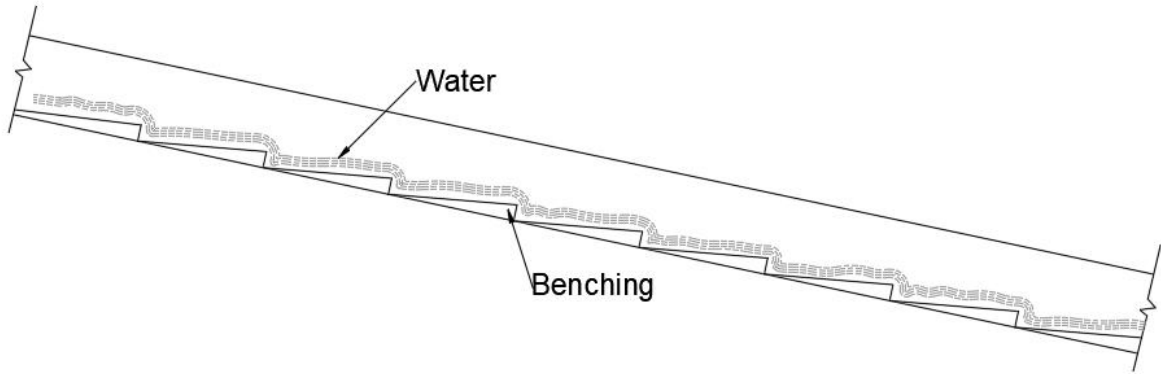

Figure 7: Concrete Dykes or Benches on steep slope provided to reduce velocity

### 5.1 Typical roadside drain

Following are the typical roadside drains:

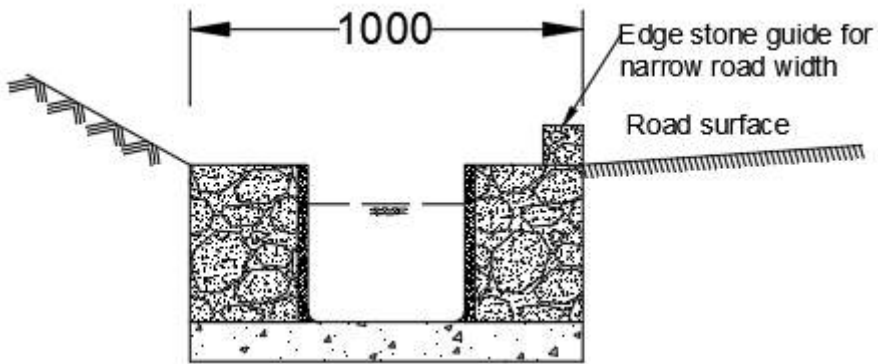

Figure 8: Typical U – Shaped Drain

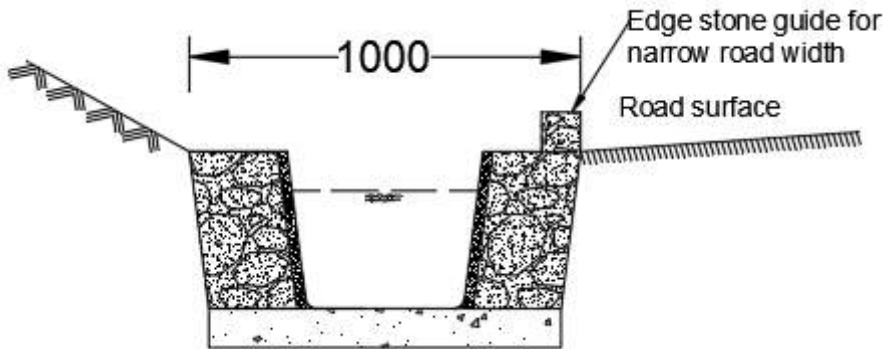

Figure 9: Typical Trapezoidal Drain

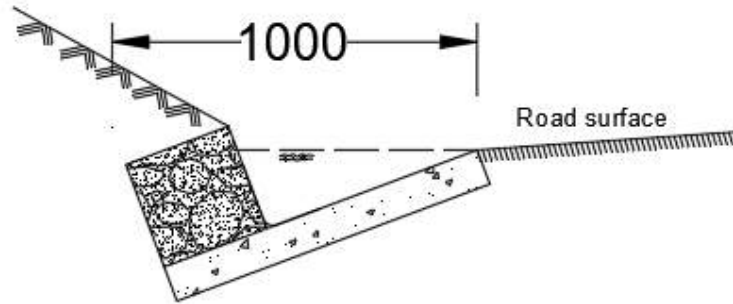

Figure 10: Typical V-Shaped Drain

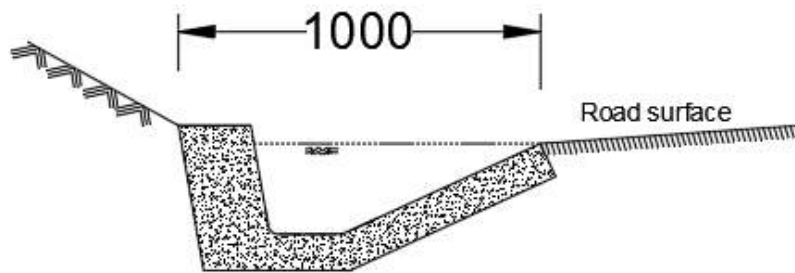

Figure 11: Typical Composite Drain

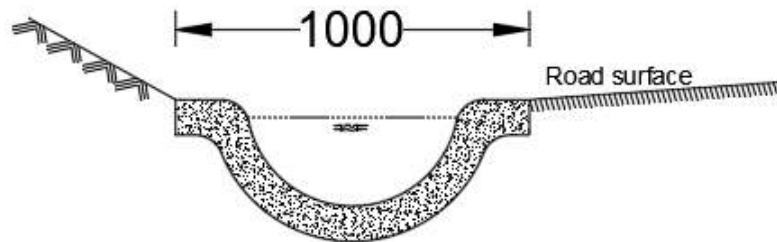

Figure 12: Typical Parabolic Drain

## 6. Drainage Construction:

The drains are normally constructed using plum concrete. Properly cured concrete has better surface hardness and can better withstand surface wear and abrasion. Curing also makes concrete more impermeable, which prevents moisture and water-borne chemicals from entering the concrete, thereby increasing durability and service life. Late spring, summer, and early fall are all typically good seasons for pouring concrete. However, you must keep an eye on the weather before and during the project. In the spring and fall, avoid rainy days and temperatures below 10°C. In the summer, avoid hot and humid heatwaves and temperatures above 30°C.

The plum concrete used during construction is specified at a ratio of 40:60 (boulder: concrete), with the concreting strength greater than M10.

One of the main concerns during the construction of drains is the plastering of the floor and riser of the drain. Failure in properly plastering the joints will lead to the seepage of water through the cracks, thus resulting in a shortening of the lifespan of the drains. The

recommended cement motor mix ratio is 1:4 with a thickness of 12 mm. In areas where the road widening is done, it has been observed that the difference in the base between the new and existing pavement causes the failure of the pavement. Thus, it is recommended that the subgrade of both the widened portion and the existing pavement be prepared monolithically.

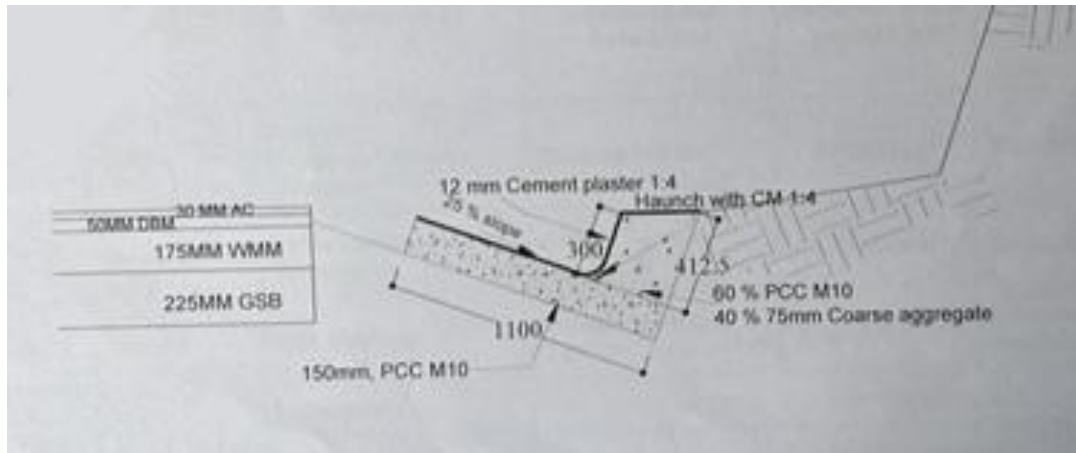

*Figure 13: Providing haunch by plastering the joints*

## 7. Cross-Drainage Works

Cross-drainages are provided to effectively dispose the water collected through the longitudinal drains and to let natural streams pass uninterrupted, especially on hilly roads. Cross-drainages consist of culverts such as Hume pipe, RCC box culverts, Slab culverts, and bridges. In hilly terrains, the location of cross-drainages are generally identified by the presence of streamlets, natural depression, or valley points. The size of the culvert is designed on the basis of the following considerations:

- Peak flow and hydraulic conveyance requirement
- Ease of maintenance and desilting operation
- Movement of debris, gravels, boulders, etc.

The minimum size of 1.2m diameter of Hume pipe culvert may be adopted on the basis of ease in access for maintenance. The minimum number of cross-drainage recommended as per the Guidelines on Design, Construction, and Maintenance of Road Infrastructure incorporating Climate-resilient Features (December 2019) is five numbers per kilometer of road. The number of cross drainages can be varied depending on the site. For example, in places where there are settlements and agricultural provisions along the road, providing a minimum of five numbers of cross-drainages per kilometer of the road cannot be feasible all the time. In cases like that, the drains should be designed based on the discharge obtained from that area such that there will be different drains of different lengths depending on the discharge.

Moreover, during the feasibility studies and preparation of a detailed project report, it is important to consider the type of drainages and number of cross drainages to be provided, especially in places which has settlements and agricultural fields along the road stretch. This will include conducting social consultations with due diligence.

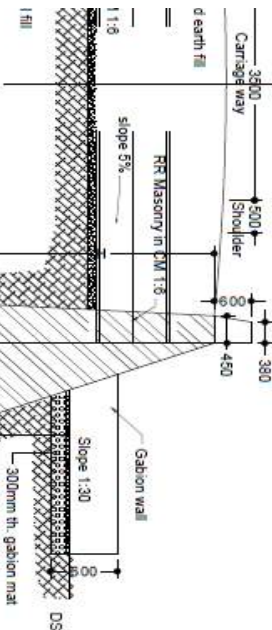

| Internal Dia (m) | Min. wall thickness (mm) | Caulking space (mm) |
|------------------|--------------------------|---------------------|
| 300              | 30                       | 18                  |
| 450              | 35                       | 19                  |
| 600              | 35                       | 19                  |
| 900              | 50                       | 19                  |
| 1200             | 65                       | 19                  |

Note : IS-458-1971

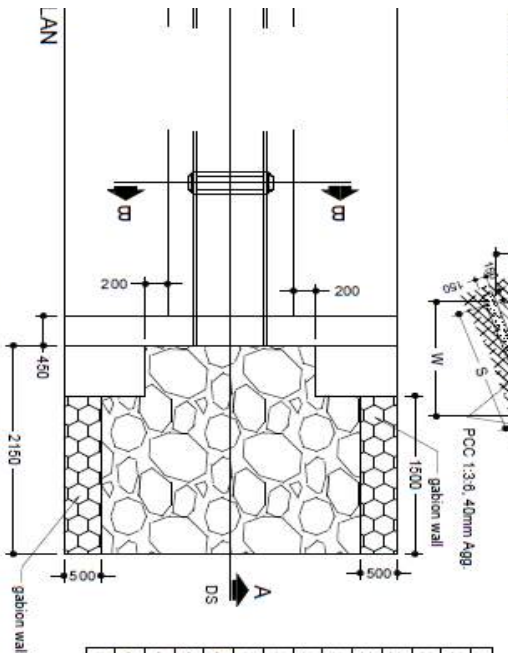

| H    | W    | h   | S    |
|------|------|-----|------|
| 2000 | 1100 | 275 | 1135 |
| 2250 | 1200 | 320 | 1240 |
| 2500 | 1300 | 360 | 1350 |
| 2750 | 1400 | 405 | 1460 |
| 3000 | 1500 | 370 | 1565 |
| 3250 | 1600 | 415 | 1680 |
| 3500 | 1700 | 455 | 1780 |
| 3750 | 1800 | 500 | 1870 |
| 4000 | 1900 | 540 | 1975 |
| 4250 | 2000 | 680 | 2105 |
| 4500 | 2100 | 625 | 2200 |
| 4750 | 2200 | 670 | 2300 |
| 5000 | 2300 | 710 | 2405 |

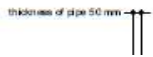

- ch pit.
2. Stone pitching is not required if catch pit is provided.
  3. The foundation depth for the walls shall be decided at site depending upon the soil condition but not less than 1250mm
  4. At least one bond stone or a set of bond stones to be provided for every 0.50 Sqm of the wall surface.

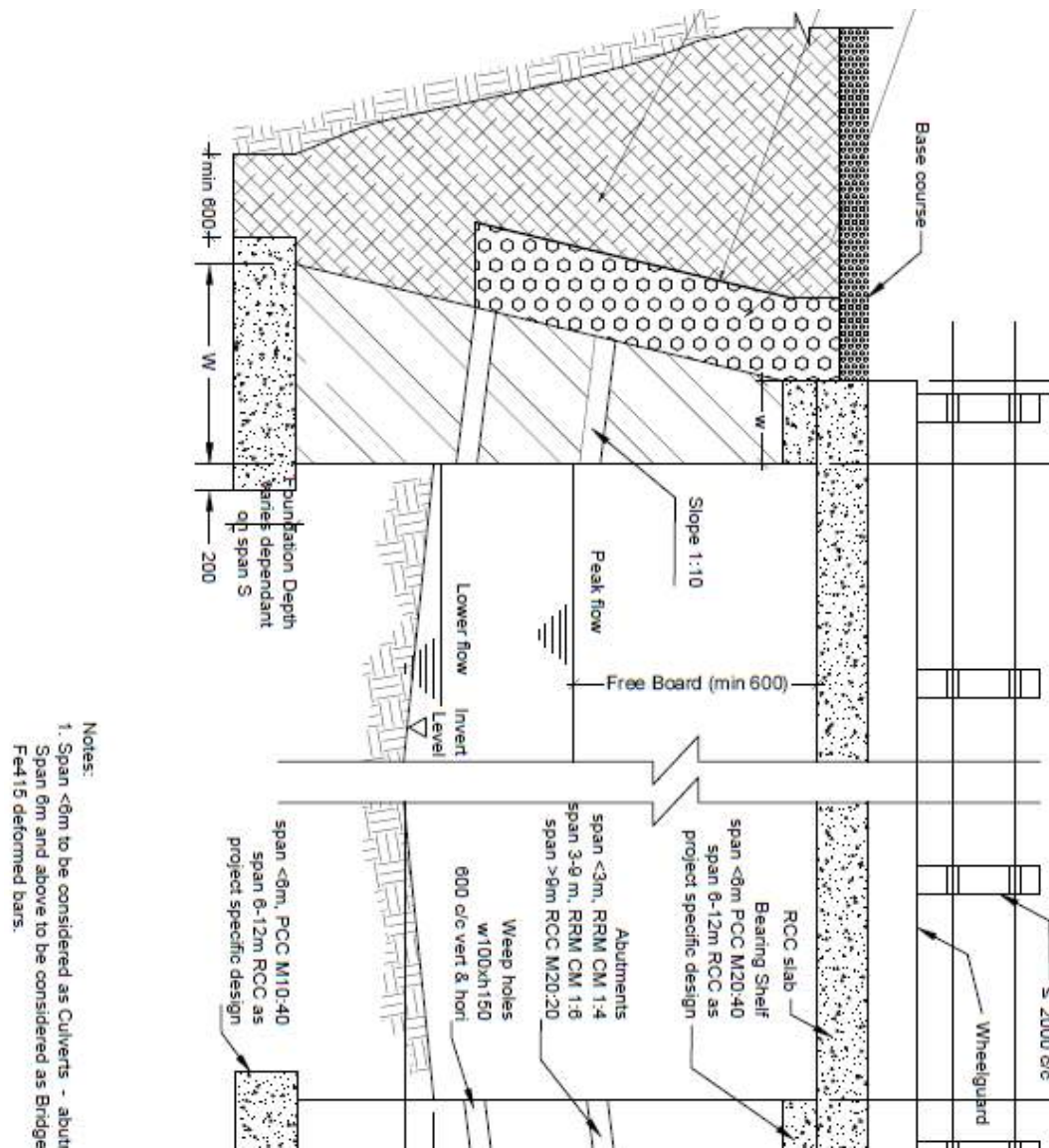

## 8. Subsurface Drainage

Subsurface drainage refers to the drainage system provided below the ground surface in order to facilitate the rapid disposal of water away from the pavement structure. Subsurface drainage plays a vital role when the road alignment passes through the unavoidable marshy area or when the alignment runs parallel to streams or rivers in close proximity. Furthermore, it is beneficial in lowering the groundwater table beneath the pavement structure, thereby preventing the capillary rise of moisture. Lack of effective subsurface drainage often leads to premature failure of pavement with the formation of cracks, settlement, rutting, and boggy action in the case of bituminous pavement. In the case of rigid pavement, it could cause a crack, fragmentation, and settlement of slab.

The movement of water below the pavement structure could be due to but not limited to the following:

- Ingress of water from the top of the pavement due to poor quality of bituminous mixes, which are permeable
- Cracks, potholes, and joints in pavement
- Improper or failed joint seals of cement concrete pavement

- The longitudinal joint between pavement and shoulder
- Earth filled medians and shoulders
- Seepage of water from the adjoining high ground in the cut sections of hilly terrain
- Impounded water level higher than the road level in the abutting agriculture fields (e.g., paddy fields)
- Capillary rise of moisture when water table is high

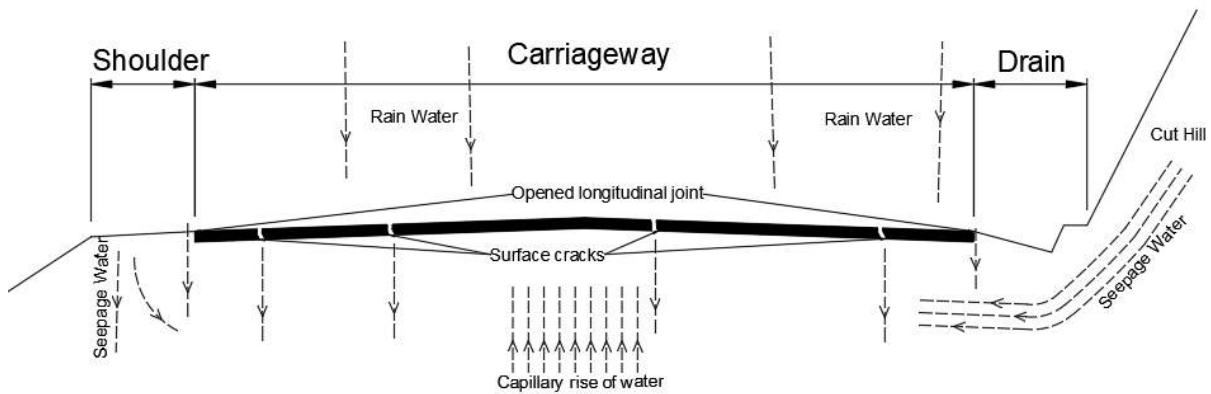

Figure 16: Sources from which water/moisture reaches lower layers of pavement

#### 8.1 Granular Sub-Base as Subsurface drainage:

GSB layer can be constructed in two layers of a minimum of 150mm in thickness, whereby one layer serves as the drainage layer (DL) and the other layer as the structural element (GSB) of the pavement. The differences between the two layers exist in the percentage of fines passing the sieve. The MORTH Specification for Road and Bridge Works (2013) proposes that out of the six grading for GSB, Grading III and IV to be used for lower sub-base and Grading V and VI for use as a Drainage Layer (DL) on top of the lower sub-base. The lower layer forms the separation/filter layer to prevent intrusion of subgrade soil into the pavement, and the upper GSB forms the Drainage Layer to drain any water that may enter through the surface cracks. A relatively dense GSB having permeability 'k' of 15 to 45 m/day was found best suited as a Drainage Layer. The water from the GSB can either be drained out to adjacent aggregate drains or extended to the edge of the slope on the valley side (day-lighted); however, it may require proper treatment, and as recommended by IRC:37, it can be treated with 2.5 % bituminous emulsion or 2% cement.

Table 4: Grading for Granular Subbase Materials

| IS Sieve Designation | The percent by Weight Passing the IS Sieve |            |             |            |           |            |
|----------------------|--|------------|-------------|------------|-----------|------------|
|                      | Grading I                                  | Grading II | Grading III | Grading IV | Grading V | Grading VI |
| 75.0 mm              | 100  | -          | -           | -          | 100       | -          |
| 53.0 mm              | 80 – 100                                   | 100        | 100         | 100        | 80 – 100  | 100        |
| 26.5 mm              | 55 – 90                                    | 70 – 100   | 55 – 75     | 50 – 80    | 55 – 90   | 75 – 100   |
| 9.5 mm               | 35 – 65                                    | 50 – 80    | -           | -          | 35 – 65   | 55 – 75    |
| 4.75 mm              | 25 – 55                                    | 40 – 65    | 10 – 30     | 15 – 35    | 25 – 50   | 30 – 55    |
| 2.36 mm              | 20 – 40                                    | 30 – 50    | -           | -          | 10 – 20   | 10 – 25    |

|          |         |         |    |    |        |       |
|----------|---------|---------|----|----|--------|-------|
| 0.85 mm  | -       | -       | -  | -  | 2 – 10 | -     |
| 0.425 mm | 10 – 15 | 10 – 15 | -  | -  | 0 – 5  | 0 – 8 |
| 0.075 mm | <5      | <5      | <5 | <5 | -      | 0 – 3 |

## 8.2 Aggregate Drains/ French Drains

Aggregate drains or the French drains could be provided below the roadside drainages to intercept water seepage from adjoining cut hill. It can also be provided in the longitudinal and lateral direction beneath the pavement structure or road shoulder to intercept and dispose of the groundwater. The minimum width of 300mm and provided up to the depth of the granular layers is recommended as per IRC: SP: 42 – 2014. The geo-filter fabric of suitable grade can be used to wrap aggregates to avoid choking the drain. The use of geotextile for subsurface drainages is found to be extremely efficient as separation and drainage layer. It also helps in the uniform distribution of load to sub-grade.

The table below gives the required gradation for Aggregate Drains as per the IRC: SP: 42 – 2014.

*Table 5: Grading Requirements for Aggregate Drains*

| Sieve Designation | Percent Passing by Weight |          |
|-------------------|---------------------------|----------|
|                   | Type A                    | Type B   |
| 63mm              | -                         | 100      |
| 37.5mm            | 100                       | 85 – 100 |
| 19mm              | -                         | 0 – 20   |
| 9.5mm             | 45 – 100                  | 0 – 5    |
| 3.35mm            | 25 – 80                   | -        |
| 600 microns       | 8 – 45                    | -        |
| 150 microns       | 0 – 10                    | -        |
| 75 microns        | 0 – 5                     | -        |

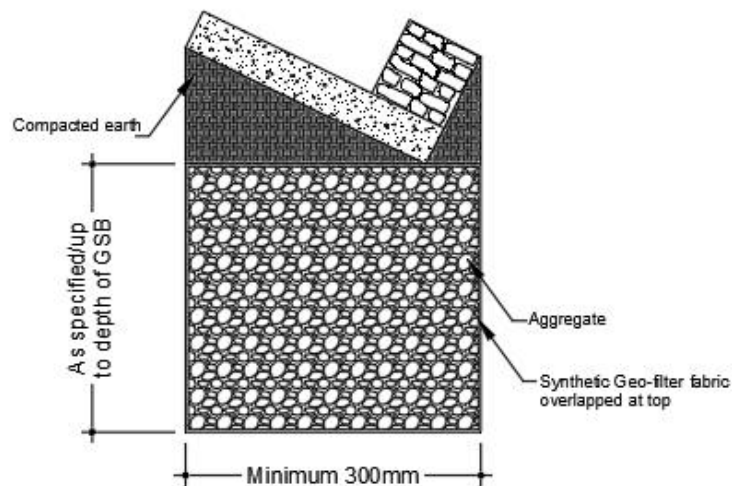

*Figure 17: Typical Subsurface drain below V-shaped drain*

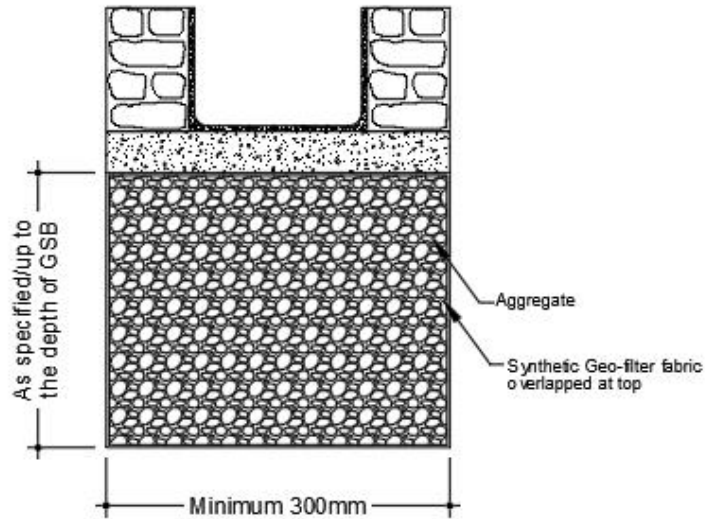

Figure 18: Typical Subsurface drain below U-shaped drain

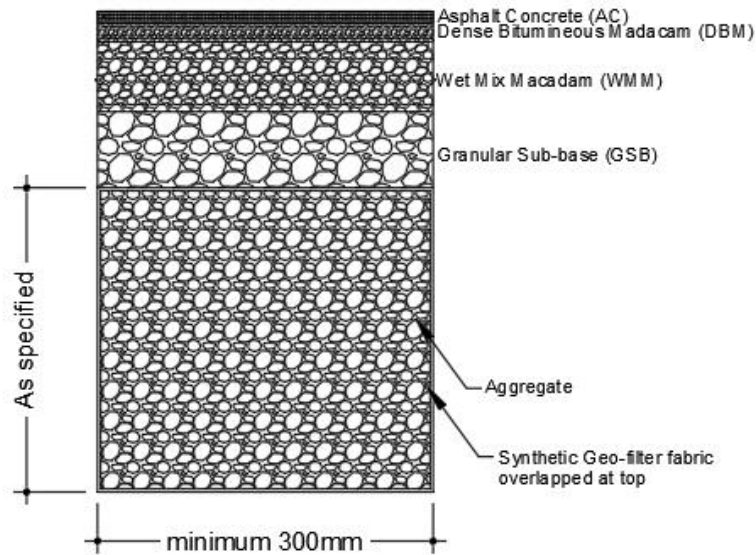
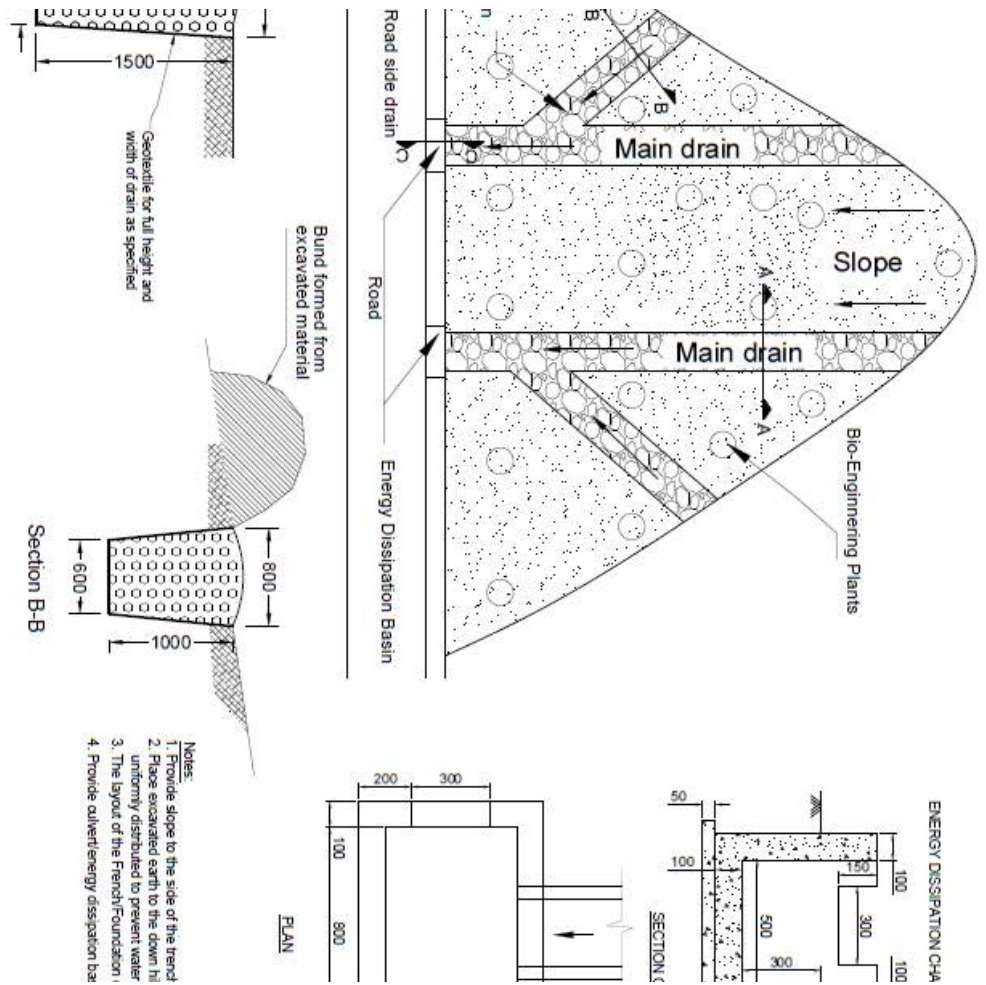
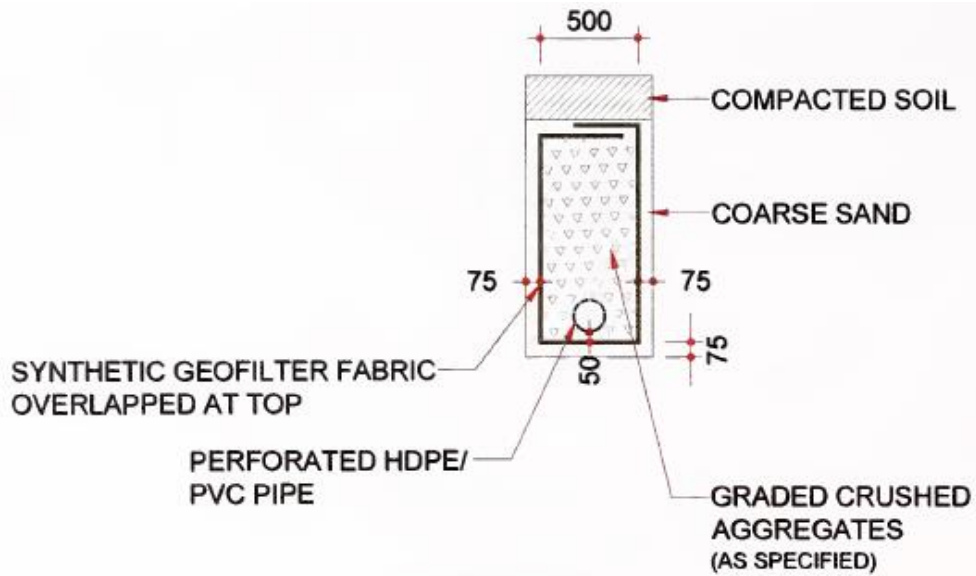

Figure 19: Typical Subsurface drain below the pavement

Aggregate drains of adequate sizes can also be provided to intercept water on the hill slope and to channel water through a designated path to be disposed of in a suitable catch pit or roadside drain, as shown in the figure below.



The aggregate drain can be provided with perforated HDPE/PVC pipe, as shown in the figure below:



**SECTION A-A**

**Cross-section of longitudinal subsurface drain (500mm wide)**

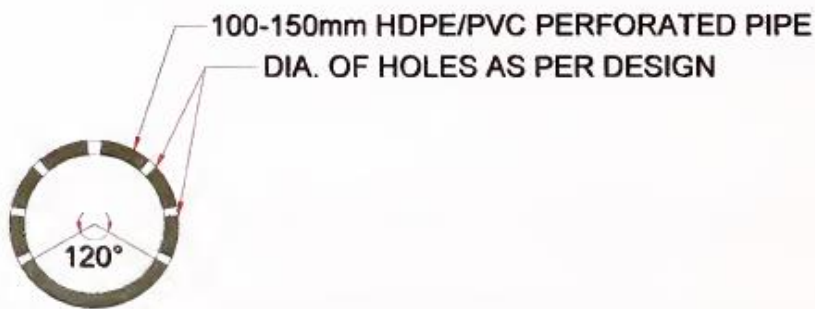

**Details of perforated HDPE/PVC pipe (with bottom 1/3 without perforation)**

*Figure 21: Perforated HDPE/PVC pipe provided with the Aggregate drain (extracted from IRC: SP:42-2014)*

## 9. Recommended Drainage size for Highways, Dzongkhag, and Farm Roads

The following *Figures 8.1* and *8.2* show the recommended type and size of the roadside drainage to be used in highways, dzongkhag roads, and farm roads located in central to northern parts of the country, which receive relatively lesser rainfall compared to the southern part. *Figure 8.3* and *8.4* is recommended for the southern part of the country, where the rainfall intensity is relatively higher.

However, in the case of irrigation water being drawn parallel to the road from a nearby stream or when the roadside drain forms a part of the irrigation water channel, it is recommended to measure the actual discharge of the irrigation water and accordingly provide the most economical and efficient drain.

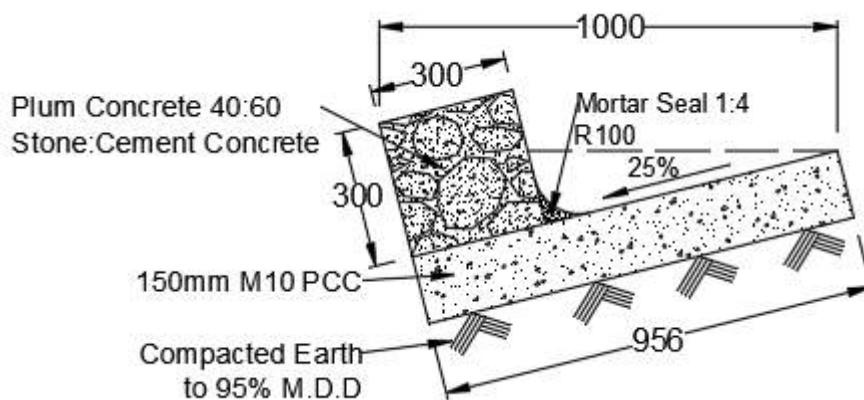

*Figure 22: Recommended V-Shaped Drain for Highways and Dzongkhag Road*

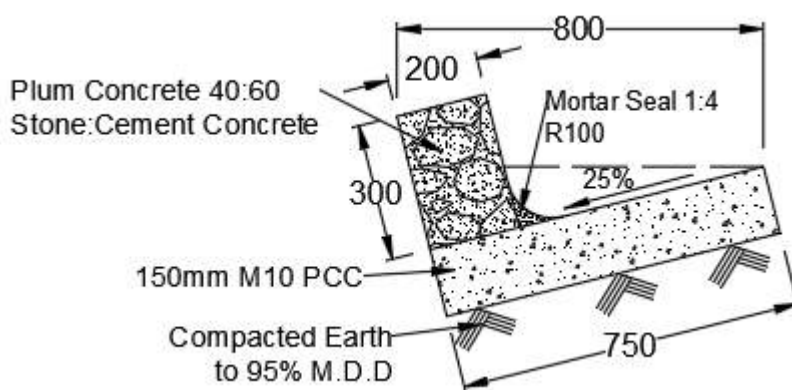

*Figure 23: Recommended V-Shaped Drain for Farm Roads*

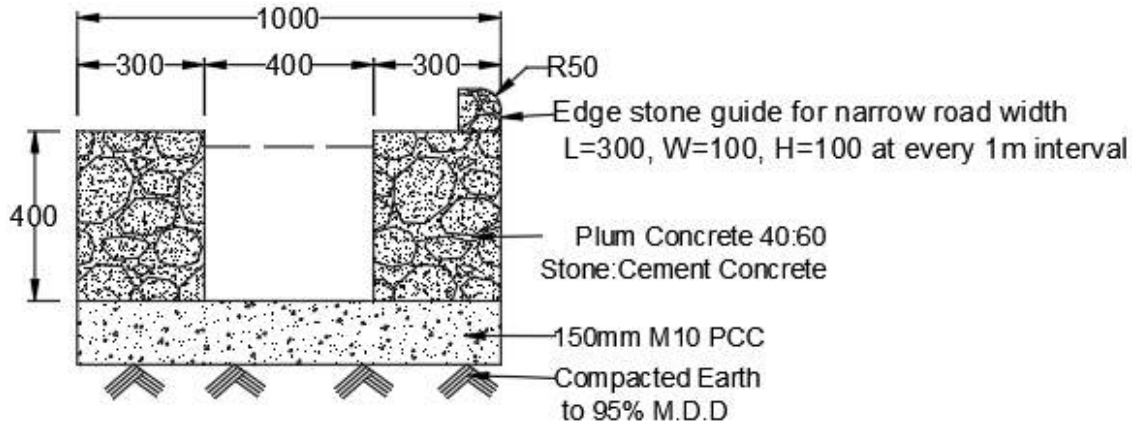

Figure 24: Recommended U-Shaped Drain for Highways and Dzongkhag Roads

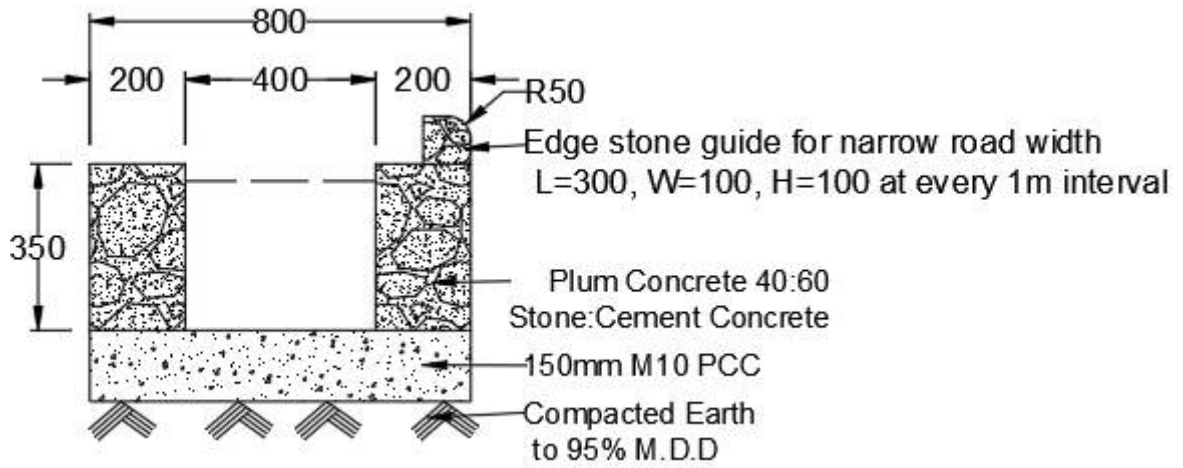

Figure 25: Recommended U-Shaped Drain for Farm Roads

## References

1. Department of Roads. (December 2019). *Guidelines on Design, Construction, and Maintenance of Road Infrastructure incorporating Climate-resilient Features*.
2. Indian Roads Congress. (2014). *Guidelines of road drainage* (1<sup>st</sup> Revision). Indian Roads Congress
3. Indian Roads Congress. (1998). *Hill road manual*. Indian Roads Congress
4. Indian Roads Congress. (2004). *Guidelines for the design of small bridges and culverts*. Indian Roads Congress
5. Ministry of Roads Transport and Highways. (2013). *Specifications for roads and bridge works* (5<sup>th</sup> Revision). Indian Roads Congress

-----THE END-----